

LSD-700+LST-41100

Automatic High Speed Flexo Printing Paper Bag Making Machine

全自动高速柔版印刷纸袋机

**简介:**

我公司最新研发的新型全自动高速纸袋机由卷筒纸到印刷、刺孔、上边胶、成筒、切袋、折底、糊底、成品袋输出一次完成。新机型操作更方便，更高效，更稳定，是生产各种不同纸质食品袋、快餐袋、面包袋、医用袋、干果袋、购物袋等等环保纸袋的理想设备。

Introduction:

My company's latest research and development of new automatic high-speed paper bag machine from the roll paper to the printing, piercing, the top of the glue, into a tube, cut bags, folding bottom, paste the finished product bag finished once. The new model is more convenient, more efficient and more stable, is the production of a variety of different paper bags, fast food bags, bread bags, medical bags, dried fruit bags, shopping bags, and so the ideal equipment for environmental protection paper bags.

特点:

1. 采用触摸屏人机界面 PC 控制系统，工作状况实时显示。
2. 超精密伺服控制系统，确保机器稳定、高效运行。
3. 材料装卸采用气动升降结构。
4. 全自动恒张力控制系统，张力从始至终丝毫不差。
5. 双光电传感器限位自动纠偏控制系统，纠偏稳定、节能、寿命长。
6. 采用触摸屏人机界面可设置的点数标记功能。
7. 精确的色标跟踪系统，色标错误自动停机。
8. 自动点数标记功能，到达设定数量纸袋自动跳出。
9. 墨水循环式封闭刮墨刀刮墨。
10. 传墨采用陶瓷网纹辊，高速运行网点再现率高，网版印刷层次分明，立体感强。
11. 按钮式 360° 连续可调纵向套准装置。

Features:

1. Adopt touch screen and PC control system, the work condition can be shown real time.
2. Equipped with accurate servo motor drive, it makes the machine run steadily and efficiently.
3. Material lifting adopt pneumatic lift structure.
4. Automatic constant tension control system. The tension will be just right from beginning to end.
5. Double photoelectric sensor limit automatic correction control system and deviation rectification stability, energy saving, long life.
6. The machine has automatic counting system. The user can set a number to count.
7. Accurate color tracking system, color errors automatically shut down.
8. The machine has automatic counting system.
9. ink-ring sealed scraping knife scraping.
10. ink Ceramic Anilox roller, high speed dot rate, screen printed layered, stronger.
11. button-360 ° continuous and adjustable longitudinal register device.

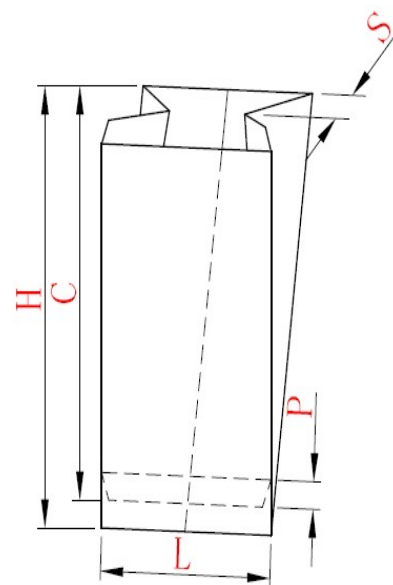
**技术参数 Technical Parameter:**

机型	Type	LSD-700+LST-41100
切袋长度 (C)	Cutting Length (C)	170-710 mm
制袋长度 (H)	Bag Length (H)	160-700 mm
制袋宽度 (L)	Bag Width (L)	80-350 mm
折边深度 (S)	Gusset Depth (S)	0-60 mm
梯口高度 (P)	Standard Flap (P)	15-18 mm
最大制袋速度	Max.Speed	600 pcs/min
纸张克重	Paper Thickness	30-100 gsm
纸卷宽度	Paper Roll Width	220-930 mm
最大纸卷直径	Max.Roll Diameter	1200 mm
纸卷内径	Reel Inner Diameter	76 mm
印刷颜色	Printing Color	4 Color
最大印刷宽度	Printing Width	1100 mm
印刷长度	Printing Length	160-800 mm
最大印刷速度	Max.Printing Speed	120 m/min
套印精度	Overprint Precision	±0.15 mm
版材厚度	Thickness of Plate	1.7 mm
总功率	Total Power	19.5 kw
机器重量	Weight of Machine	7200 kg
外形尺寸	Overall Dimension(LxWxH)	9300x1800x1850 mm

注意:

制袋速度取决于材料和胶粘剂的品质、纸袋尺寸、操作员的工作知识和工作方法。

Note:

Machine speeds dependent on paper & adhesive qualities, bag dimensions, operator knowledge, and general work philosophy.